

Single Arm Fixed Reach E-32-F, J-32-F

Primarily used to load and unload railcars through open domes in installations where the cars can be accurately spotted. The single arm configuration can also be used for tank truck applications. Some allowance for mis-spotting is possible with the single arm and increases as the diameter of the hatch opening increases.

This simple arm incorporates only three swivel planes of rotation and is designed for use in top loading installations where the vehicle is located at a fixed distance from the riser pipe. The two swivel planes at the inlet permit both up-and-down and side-to-side movement of the assembly, and the third swivel plane allows the drop pipe to remain vertical.

Valves can be located inboard or outboard to facilitate loading. With a valve located outboard, drippage of viscous products after loading can be minimized.

The single arm loader is adaptable to tight fill or closed system loading when equipped with additional swivel planes of rotation and/or drop hose, along with required outboard coupling, union or fitting.

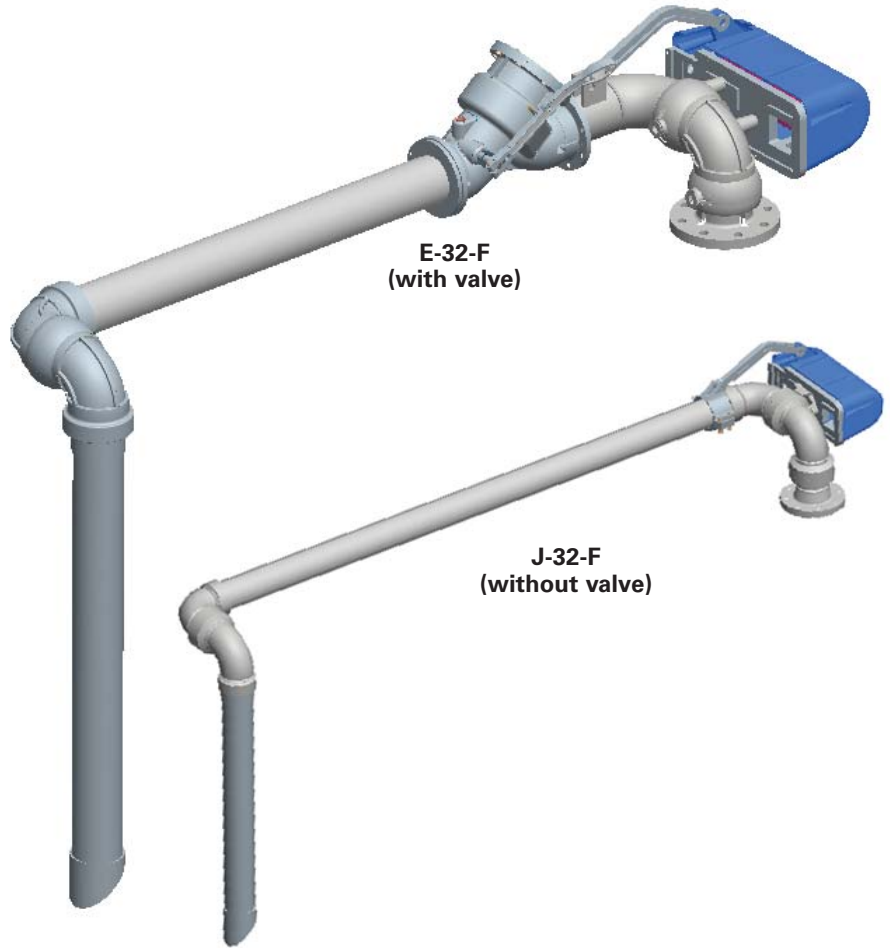

Benefits

- Adaptable to tight-fill or closed system loading when equipped with additional swivel planes of rotation and/or drop hose; along with required outboard coupling, union or fitting
- Rail or truck applications
- Smooth, easy operation

Features

- Available in 2", 3" and 4"
- Available in carbon steel, stainless steel, aluminum and special alloys
- Choice of flanged, threaded or all-welded construction

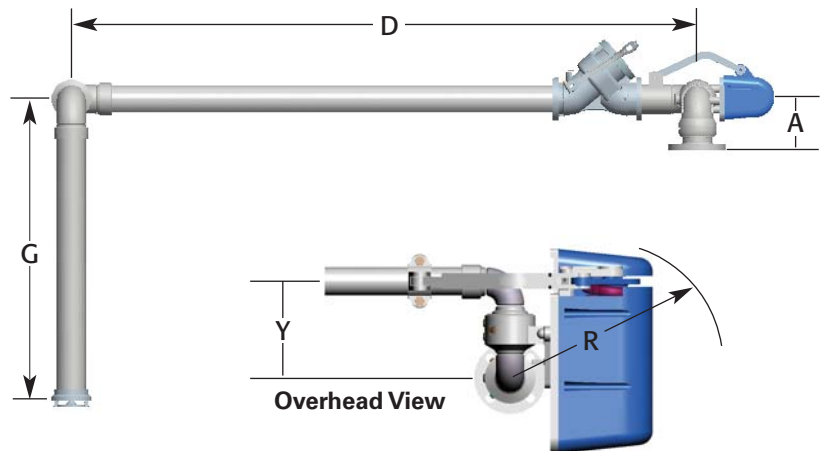

Dimensions*

Size	A		D		G		R		Y		
	in.	mm	in.	mm	in.	mm	in.	mm	in.	mm	
2"	51	8-5/8	219	120	3048	48	1219	17	432	8-1/8	206
3"	76	10-1/2	267	120	3048	48	1219	18-1/2	470	10-3/4	273
4"	102	11-3/4	298	120	3048	48	1219	20	508	12-3/4	324

*Custom dimensions also available.

IMPORTANT: OPW products should be used in compliance with applicable federal, state, provincial, and local laws and regulations. Product selection should be based on physical specifications and limitations and compatibility with the environment and materials to be handled. OPW MAKES NO WARRANTY OF FITNESS FOR A PARTICULAR USE. All illustrations and specifications in this literature are based on the latest product information available at the time of publication. OPW reserves the right to make changes at any time in prices, materials, specifications and models and to discontinue models without notice or obligation.