

| # | Description | Qty | Material | Part # | |
|----|---------------------------|-------------|--|--|---|
| 1 | Body | 1 | Aluminum A356-T6, ASTM B26 Anodized. | E20064AH | |
| 2 | Spirol Pin | 7 | Carbon Steel Zinc Plated. | H31396M | |
| 3 | Interlock Spring | 2 | Carbon Steel Zinc Plated. | H31743M | |
| 4 | Interlock | 2 | 316 SST, ASTM A351 CF-8M. | C20062M | |
| 5 | Cam Spring | 5 | 18-8 SST. | H06753M | |
| 6 | Cam | 5 | 316 SST, ASTM A351 CF-8M. | C20063M | |
| 7 | Wave Spring | 1 | 17-7 PH SST, Condition H900 Hardened. | H31091M | |
| 8 | Cylinder | 1 | Aluminum 6061-T6. | C21283AH | |
| 9 | Cylinder O-Ring | 1 | See Seal Options Chart. | - | * |
| 10 | Nose Seal | 1 | See seal Options Chart. | - | * |
| 11 | Poppet | 1 | Aluminium A356-T6, ASTM B26, Anodized. | D20069AH | |
| 12 | High Pressure Link | 2 | 410 SST Hardened. | H30552M | |
| 13 | Clevis Pin | 2 | 17-4 PH SST, Condition H900 Hardened. | H30610RE | |
| 14 | Washer | 2 | 18-8 SST. | H30206M | |
| 15 | E - Ring | 2 | SST | H30554M | |
| 16 | Drive Link | 1 | 316 SST, ASTM A351 CF-8M. | C21255EW | |
| 17 | Sleeve | 1 | Aluminum A356-T6 ASTM B26 Anodized. | E20013AH (1004D3) E20026AH (1005E3) | |
| 18 | Dust Seal | 1 | Felt | H30214M | |
| 19 | Tube Spacer | 1 | 316 SST. | C21254RE | |
| 20 | Handle Shaft | 1 | 13-8 Condition RH 950 Stainless Steel. | C21290RE | |
| 21 | Stuff Box | 1 | 316L ASTM A479 316. | C20812RE | |
| 22 | Stuff Box O-Ring | 2 | See Seal Options Chart. | - | * |
| 23 | Stuff Box O-Ring | 1 | See Seal Options Chart. | - | * |
| 24 | Sleeve Bearing | 1 | 97180 | H32163M | * |
| 25 | Operating Handle | 1 | 316 SST, ASTM A351 CF-8M. | E20070EW | |
| 26 | Cam Follower | 1 | 17-4 PH SST, Condition H900 Hardened. | H32029RE | |
| 27 | Loctite | As required | Thread Locking Compound. | TYPE 242 | |
| 28 | 3/8-24 Hex Nut | 1 | Carbon Steel Zinc Plated. | H30220M | |
| 29 | Belleville Disc Spring | 1 | 300 Series Stainless Steel | H32158M | |
| 30 | Nut, Hex, SST, M10-1.5 | 1 | SST | H32111M | |
| 31 | ID Tag | 1 | 0.12 Satin. | - | |
| 32 | 6-20 X 3/16" Thread Screw | 4 | Type B, Steel, Zinc plated | H32149M | |

* Items included in seal replacement kits (1004D3SRK)

IMPORTANT: OPW products should be used in compliance with applicable federal, state, provincial, and local laws and regulations. Product selection should be based on physical specifications and limitations and compatibility with the environment and materials to be handled. OPW MAKES NO WARRANTY OF FITNESS FOR A PARTICULAR USE. All illustrations and specifications in this literature are based on the latest product information available at the time of publication. OPW reserves the right to make changes at any time in prices, materials, specifications and models and to discontinue models without notice or obligation.

SEAL OPTIONS

| Seal Material | Coupler Model # | Nose Seal (10) | Stuff Box Seal (22) | Stuff Box Seal (23) | Cylinder Seal(9) | Temp Rating |
|---------------|-------------------------|----------------|---------------------|---------------------|------------------|----------------------------------|
| Buna N 1500 | 1004D3-0401/1005E3-0401 | H30482M | H20129M | H31705M | H30258M | -20°F - 250°F (-29°C - 121°C) |
| Fluorocarbon | 1004D3-0402/1005E3-0402 | H30483M | H20175M | H31706M | H30217M | -20°F - 400°F (-29°C - 204°C) |
| EPT E 692 | 1004D3-0404/1005E3-0404 | H31957M | H20176M | H31707M | H31956M | -50°F - 225°F (-46°C - 107°C) |

Consult factory for additional seal options.

SEAL REPLACEMENT KITS

OPW 1004D3SRK Seal Replacement Kits include everything needed to change the seals in the 1004D3/1005E3 API coupler. **Seal Replacement Kits are always recommended as spare parts.**

| Seal Material | Seal Replacement Kit Part # |
|---------------|-----------------------------|
| Buna N 1500 | 1004D3SRK-0401 |
| Fluorocarbon | 1004D3SRK-0402 |
| EPT E 692 | 1004D3SRK-0404 |
| 97180 | H32163M |

Tools Needed

- 11/16 inch or 17mm socket
- 1 1/4 inch or 32mm deep reach socket.

ASSEMBLY

API coupler Installation Preparations

Safety precautions

Warning: Read & Understand these instructions before starting installation.

- Coupler to be used for its designated purpose only.
- Local regulations for (un)loading must be followed at all times.
- Product flow may result in static electricity; grounding of equipment is required.
- **Although the 1004D3/1005E3 designed for higher pressures, proper measures must be taken within the system to allow for thermal expansion.**
- OPW instructions must be followed for installation.

Make sure to use adequate personal protection at all times during operation.

Note: All images depict the 1004D3 (large handles). The steps for 1005E3 coupler (small handles) are the same as 1004D3

Step 1

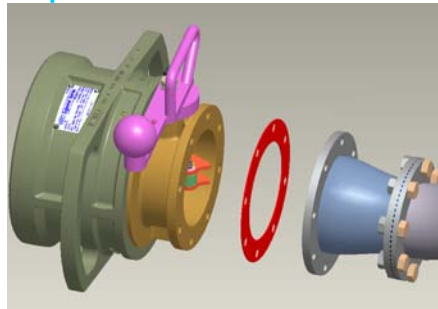

- Secure whatever device coupler will be mounted to the e.g. loading arm.
- Sandwich gasket between coupler and load device flanges.

Step 2

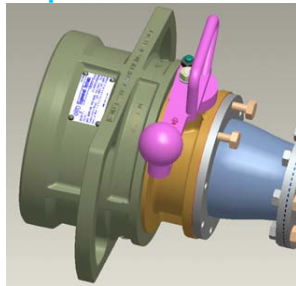

- Align coupler bolt holes with bolt holes on loading device.
- Insert two bolts into the highest bolt holes on the flange and hand tighten. This is to secure coupler, and prevent damage due to bending as the remaining bolts are installed.

Warning: Under pressure, poppet will cause handle to rotate violently if not restrained.

Step 3

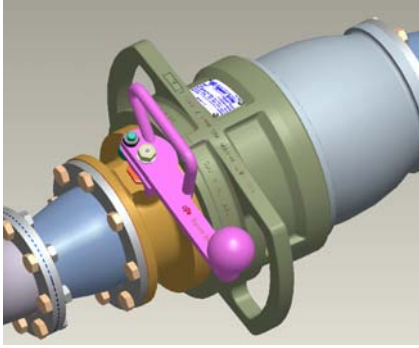

- Connect the coupler to the adapter. Slide the sleeve fully forward. Fully rotate the operating handle and in the open position, the operating handle cam surface should prevent the sleeve from sliding back.

MAINTENANCE

Consider the following when servicing the coupler:

- When coupler is over pressurized, it must be inspected thoroughly.
- After maintenance is performed, it must be tested before the next use (see coupler Testing).
- Periodical inspection (every 3 months) for leakages (especially with toxic or hazardous mediums).
- Maintenance must be performed by authorized personnel.
- Periodical maintenance (once a year) is required according to the maintenance instructions.
- When any leakages are found, have seals replaced immediately to obtain a safe and correct use of the coupler. If leakages continue contact the OPW distributor or the OPW Engineered Systems for consultation.

DISASSEMBLY INSTRUCTIONS

Step 1: Dismantle API coupler

Attention: Dismantling must be performed by authorized and trained personnel only.

Attention: The same risks and procedures of initial installation apply.

Warning: Make sure what kind of medium has been or is being loaded with this coupler, reading the manuals provided with the coupler. When the medium is unclear, hazardous or toxic, one is obligated to clean the parts with the help of specialized personnel, companies or governments.

Before dismantling coupler make some necessary preparations

Figure A

- Secure from movement the device the coupler is attached to (Figure A)

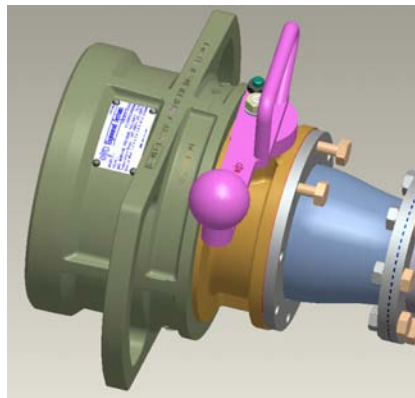
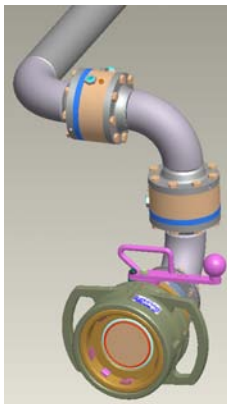

Figure B

- **Make sure to use adequate personal protection at all times during the operation.**
- Clear surrounding areas and shut off any working devices.
- Make sure the surrounding area is clear from obstacles.
- Barricade surrounding area, so no unauthorized persons can access work floor.
- Arrange necessary permits or paperwork with plant holder, owners or local authorities, before taking any actions.

When the coupler is clean and dry and the necessary preparations have been made, the coupler can be disassembled from the device it is attached to.

- With the corresponding loading arm secured from movement, loosen bolts mounting the coupler to the loading arm. Support coupler while removing all bolts except top two. This is to prevent bending moments from causing damage to the flanges and bolts (Figure B).
- While supporting the loose coupler, remove the final two bolts. Coupler should fall away.
- Remove gasket between both flanges.

Step 2:

Carefully, manually defeat the interlocks and slide the sleeve fully forward. Fully rotate the operating handle.

Step 4:

Remove the stuff box, seals and Sleeve Bearing. Remove the stuff box using the 1 1/4 inch or 32mm deep reach socket.

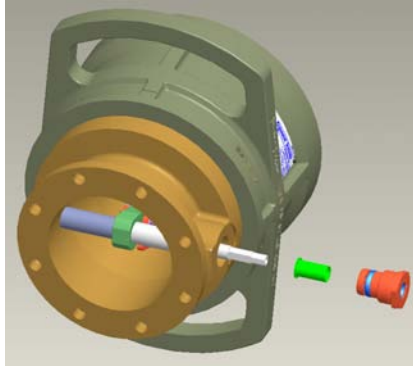

Step 6:

Remove the poppet assembly, cylinder and cylinder wave spring.

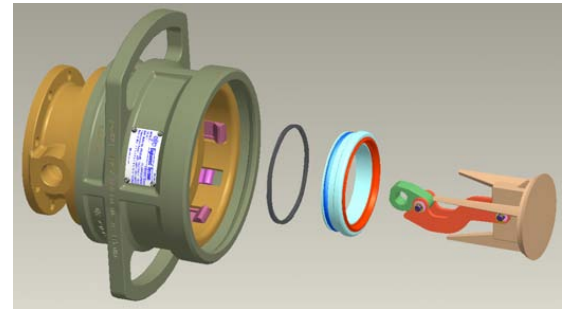

Step 3: Disassemble:

Remove the 10mm nut and Belleville washer using the 11/16 inch or 17mm socket.

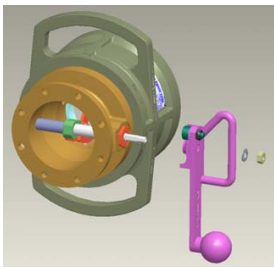

Step 5:

Remove the handle shaft through the body being careful to catch the tube spacer. Thoroughly clean the handle shaft and tube spacer and inspect for wear or damage.

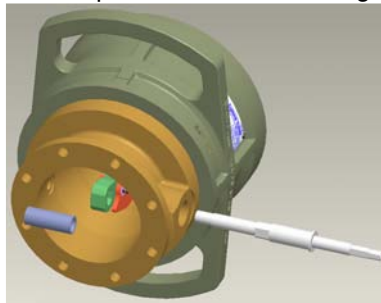

Step 7:

Remove the nose seal and O-ring from the cylinder. Thoroughly clean the cylinder and inspect for wear or damage.

Step 8:

Remove the 3 O-rings from the stuff box. Use the seal pick provided in the seal kit to remove the internal O-ring. Note: The inner most stuff box O-ring may remain on the handle shaft after the stuff box is removed. If required, remove the sleeve bearing from the stuff box. Thoroughly clean the stuff box and inspect for wear or damage.

ASSEMBLY INSTRUCTIONS

Step 1:

Replace the nose seal and the cylinder O-ring. Lubricate the O-ring with light oil.

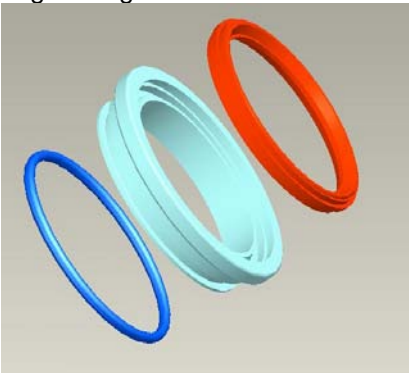

Step 2:

Replace the interior, exterior O-rings and the sleeve bearing in the stuff box. Lubricate the O-rings with light oil.

Step 3:

Reinstall the cylinder wave spring and cylinder then the poppet assembly into the body. **Important:** Note orientation of high pressure links to the through hole in the body.

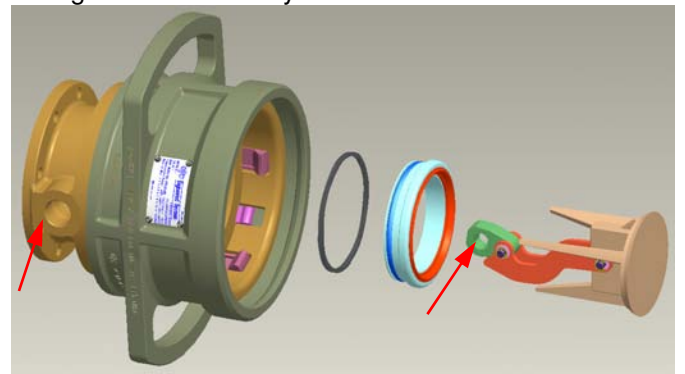

Step 4:

Slide the handle shaft into the body and through the drive link. As the shaft just pokes through the drive link, install the tube spacer. Rotate the shaft until the flats on the shaft and the drive link align and then push the shaft through and into the body.

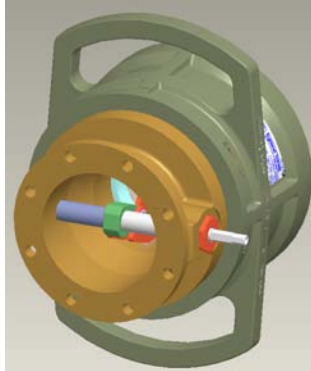

Step 5:

Install the stuff box using the 1 1/4 inch or 32mm deep reach socket. Tighten the stuff box firmly into the body.

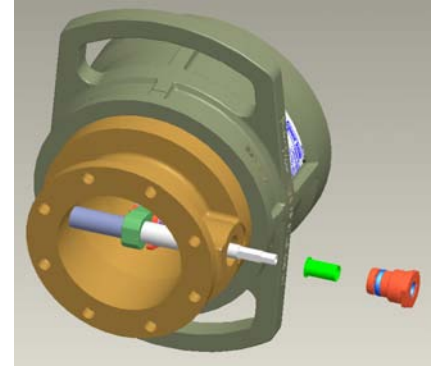

Step 6:

Install the operating handle, Belleville washer and 10mm nut. The Belleville washer is cone shaped. Install this washer such that the bottom of the cone is in contact with the operating handle. Tighten the 10mm nut using the 11/16 inch or 17mm socket to compress the washer as much as possible.

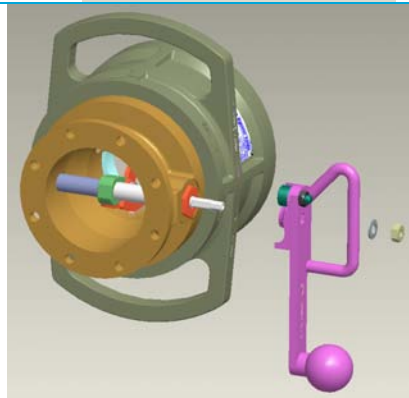

Step 7:

Fully rotate the operating handle to close the coupler and slide the sleeve all the way back.

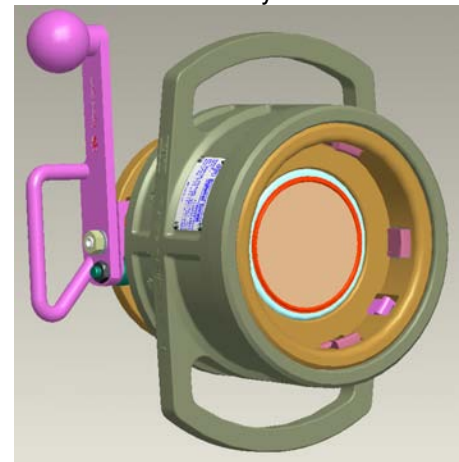

Assembly Complete

Warning: With sleeve forward, operating handle is unlocked and can rotate. Do not apply pressure to handle unless trying to open valve. Use caution when working around handle when system is under pressure. Once handle starts moving pressure can cause it to rotate violently.

WARNING

Failure to follow these warnings could result in serious personal injury, property damage or product failure.

1) Do not attempt any maintenance service while the equipment is in operation. System pressure must be relieved and the product drained before attempting any service on the unit. The line must be locked out while service is in progress. Proper thermal relief must be provided at all times while equipment is in service.

2) OPW products do not eliminate possible exposure to hazardous substances. The conditions of handling and use are beyond our control, and we make no guarantee and assume no liability for damages or injuries related to the use of our products. Follow the safety precautions outlined in the Material Safety Data Sheets for the material being used. It is the responsibility of the user to comply with all federal, state and local regulations. Always employ proper safety precautions and handling techniques.

3) Proper seal and wetted material part selection is critical for safe operation. To assure maximum life for the service intended, use only those materials compatible with the fluids being handled. Please note material being supplied and make certain that it is suited for the intended service.

Engineered Systems

2726 Henkle Drive
Lebanon, OH 45036 USA
Telephone: 513-696-1500
Toll Free: 800-547-9393
Fax: 513-932-9845
www.opw-es.com